

Overview

The **BA/T1xx-O** is for Outside Air mounting and temperature measurement. The probe is made to protect the sensor from impediments such as, rain, sleet, snow or bird droppings. The 4 to 20mA transmitter can be ordered with 100Ω (385), 1KΩ (385) RTDs or 10KΩ type 2 thermistor sensors. A 0 to 5VDC or 0 to 10VDC transmitter is also available with a 10KΩ type 2 thermistor sensor. Special high accuracy RTD matched transmitters (M) are available which use class A RTD's and match the sensor to the transmitter for improved accuracy. Enclosure mounting styles come in plastic or metal for both NEMA 3R and NEMA 4 applications and are all UV rated.

Identification

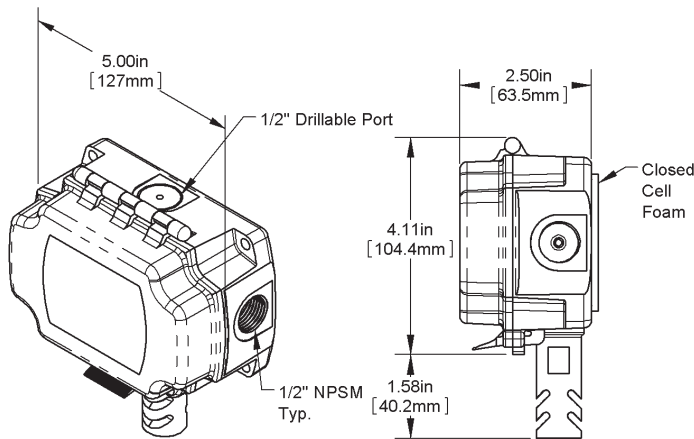

Fig 1: Outside Air Sensor in a BAPI-Box (**BB**) Enclosure

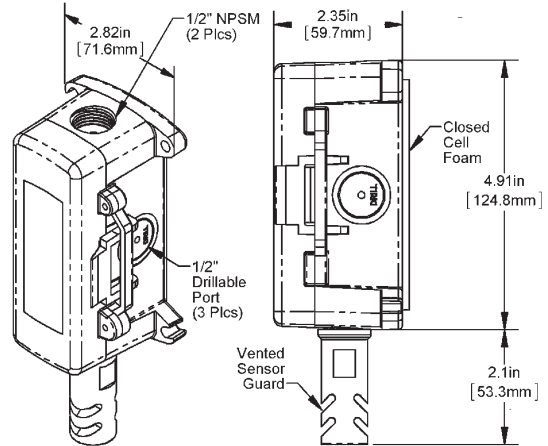

Fig 2: Outside Air Sensor in a BAPI-Box 2 (**BB2**) Enclosure

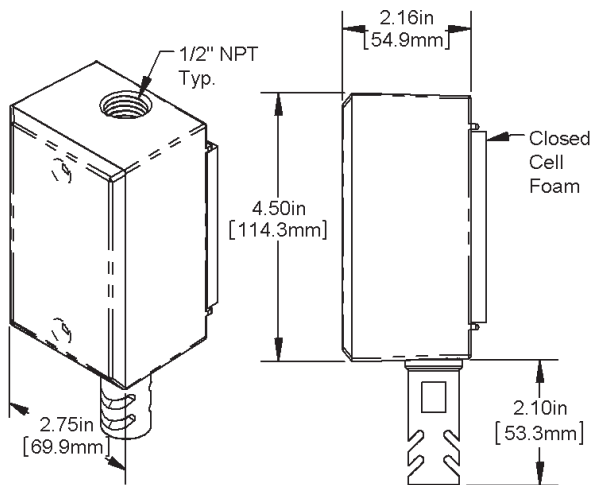

Fig 3: Outside Air Sensor in a Weatherproof (**WP**) Enclosure

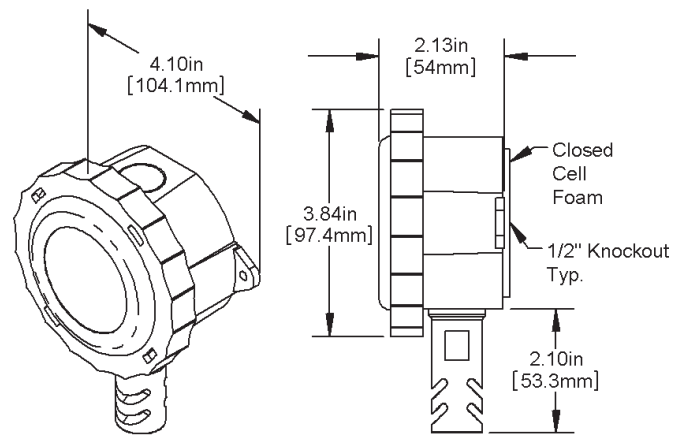
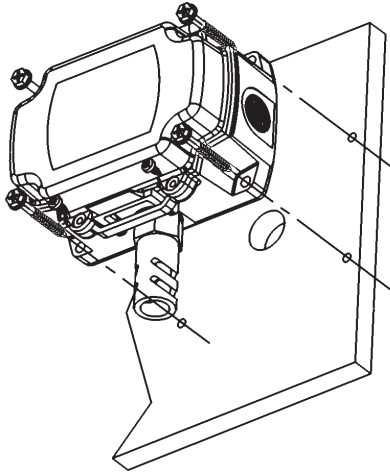
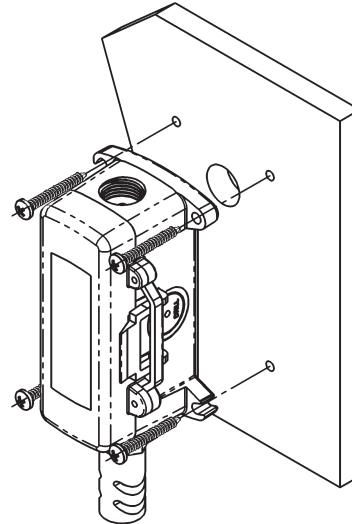
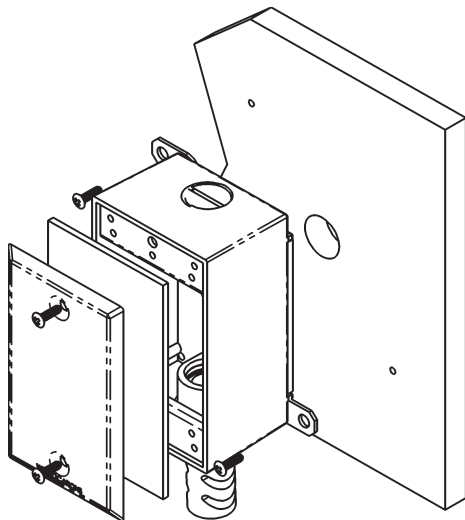
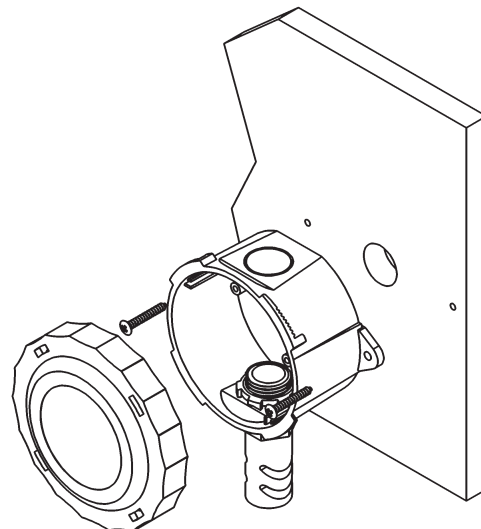

Fig 4: Outside Air Sensor in a Weather Tight (**EU**) Enclosure

Mounting**Fig 5: BAPI-Box (BB) Enclosure Installation****Fig 6: BAPI-Box 2 (BB2) Enclosure Installation****Fig 7: Weatherproof (WP) Enclosure Installation****Fig 8: Weather Tight (EU) Enclosure Installation**

Outside Air (OSA) sensor placement is critical to good performance. The OSA sensor must be mounted in the shade away from building windows, doors or vents. They should never be in direct sunlight or you will have higher than expected temperature readings by as much as +30%. The ideal shaded location in the Northern hemisphere is on the North side of the building. In the Southern hemisphere the South side of the building is ideal.

The sensor shield and probe should always point down and mounted between four feet above the ground/roof and one foot minimum below the eave. (Note: Four feet keeps the sensor above the ground or roof top radiation and one foot under the eave prevents measurement of trapped heat from under the eave.)

Drill the mounting holes and mount as shown in the figures 5-8. Snug up the mounting screws to ensure that the foam backing compresses to about 50% of its thickness to make a gasket type seal against the wall surface.

Route the wires into the box and terminate with sealant filled connectors to prevent water from attacking the connection, thereby preventing costly callbacks. Best practice is to caulk the wiring hole after the wiring is installed. Close the cover of the BB, BB2 or WP boxes and secure with provided cover screws or twist on the cover of the EU box to the second click.

Wiring & Termination

BAPI recommends using twisted pair of at least 22AWG and sealant filled connectors for all wire connections. Larger gauge wire may be required for long runs. All wiring must comply with the National Electric Code (NEC) and local codes. Do NOT run this device's wiring in the same conduit as high or low voltage AC power wiring. BAPI's tests show that inaccurate signal levels are possible when AC power wiring is present in the same conduit as the sensor wires.

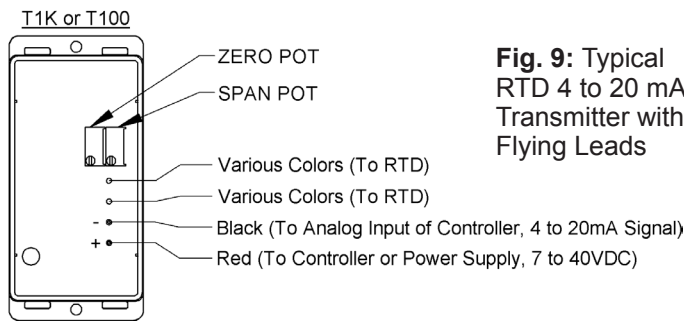

Fig. 9: Typical RTD 4 to 20 mA Transmitter with Flying Leads

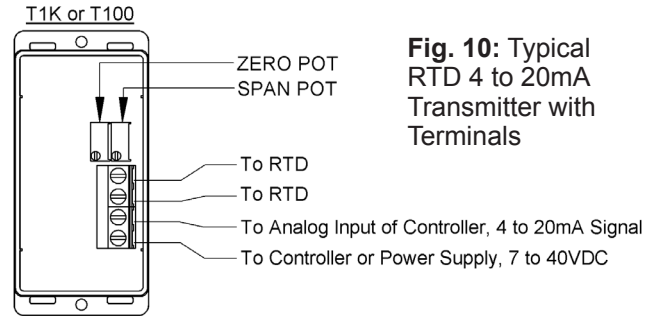

Fig. 10: Typical RTD 4 to 20mA Transmitter with Terminals

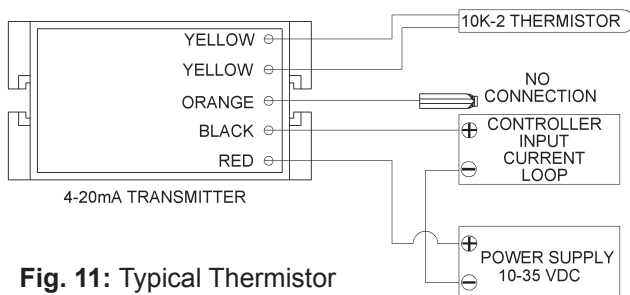

Fig. 11: Typical Thermistor 4 to 20mA Transmitter

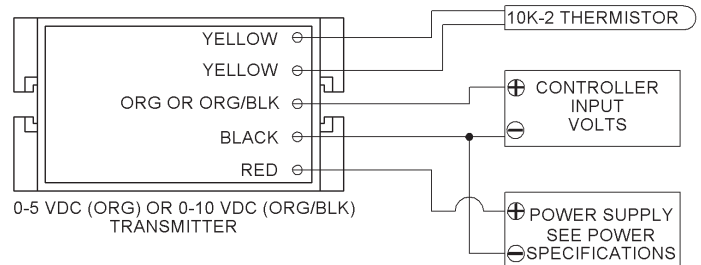

Fig. 12: Typical Thermistor Voltage Transmitter

Diagnostics

Possible Problems:

- Unit will not operate.
- The reading is incorrect in the controller.

Possible Solutions:

- Measure the power supply voltage by placing a voltmeter across the transmitter's (+) and (-) terminal. Make sure that it matches the drawings above and power requirements in the specifications.
- Check if the RTD wires are physically open or shorted together and are terminated to the transmitter.
- Measure the physical temperature at the temperature sensor's location using an accurate temperature standard. Disconnect the temperature sensor wires and measure the temperature sensor's resistance with an ohmmeter. Compare the temperature sensor's resistance to the appropriate temperature sensor table on the BAPI web site.
- Determine if the input is set up correctly in the controllers and BAS software.
- For a 4-20mA current transmitter measure the transmitter current by placing an ammeter in series with the controller input. The current should read according to the "4-20mA Temperature Equation" shown below.
- For a voltage transmitter, measure the signal with a volt meter (Orange or Orange/Black to Black). The signal should read according to the "Voltage Temperature Equation" shown below.

Voltage Temperature Equation

$$T = T_{Low} + \frac{(V \times T_{Span})}{V_{Span}}$$

- T = Temperature at sensor
- T_{Low} = Low temperature of span
- T_{High} = High temperature of span
- T_{Span} = T_{High} - T_{Low}
- V_{Low} = Low transmitter voltage usually=(0, 1 or 2v)
- V_{High} = High transmitter voltage usually=(5 or 10v)
- V_{Span} = V_{High} - V_{Low}
- V = Signal reading in volts

4-20mA Temperature Equation

$$T = T_{Low} + \frac{(A - 4) \times (T_{Span})}{16}$$

- T = Temperature at sensor
- T_{Low} = Low temperature of span
- T_{High} = High temperature of span
- T_{Span} = T_{High} - T_{Low}
- A = Signal reading in mA

Specifications subject to change without notice.



Outside Air (OSA) Temperature Transmitters

BA/T1# -O Temperature Sensor

Installation & Operations

20920_ins_OSA_Active

rev. 06/30/15

Specifications

RTD Transmitter

Power Required: 7 to 40VDC
 Transmitter Output: 4 to 20mA, 850Ω@24VDC
 Output Wiring: 2 wire loop
 Output Limits: <1mA (short), <22.35mA (open)
 Span: Min. 30°F (17°C), Max 1000°F, (555°C)
 Zero: Min. -148°F (-100°C), Max 900°F (482°C)
 Zero & Span Adjust: 10% of span
 Accuracy: ±0.065% of span
 Linearity: ±0.125% of span
 Power Output Shift: ±0.009% of span
 RTD Sensor: 2 wire Platinum (Pt), 385 curve
 Transmitter Ambient: -4 to 158°F (-20 to 70°C)
 0 to 95% RH, Non-condensing

Thermistor Transmitter

Supply Voltage:
 10 to 35 VDC (0 to 5 VDC or 4 to 20 mA Outputs)
 15 to 35 VDC (0 to 10 VDC Output)
 12 to 24 VAC (0 to 5 VDC Outputs)
 15 to 24 VAC (0 to 10 VDC Output)
 Transmitter Output: 4 to 20mA, 700Ω@24VDC
 0 to 5 & 0 to 10VDC, 10KΩ min
 Output Wiring: 2 & 3 wire (See wiring detail on pg. 3)
 Transmitter Limits: -40 to 185°F, (-40 to 85°C)
 Accuracy: ±1.015°C, from (0 to 65°C)
 Linearity: ±0.065°C, from (0 to 65°C)
 Resolution: Span/1024
 Thermistor Sensor: 10K-2 Thermistor, 10KΩ @77°F
 Transmitter Ambient: 32 to 158°F, (0° to 70°C)
 0 to 95% RH, Noncondensing

Thermistor: 10K-2, Thermal Resistor (Bare Sensor)
 Accuracy (Std): ±0.36°F, (±0.2°C)
 Accuracy (High): ±0.18°F, (±0.1°C), [XP] option
 Stability: < 0.036°F/Year, (<0.02°C/Year)
 Heat Dissipation: 2.7 mW/°C
 Probe Range: -40° to 221°F (-40° to 105°C)
 Wire Colors:
 Standard: Yellow/Yellow (no polarity)
 High Acc. [XP]: Yellow/Yellow (no polarity)

RTD: Resistance Temp Device (Bare Sensor)
 Platinum (Pt): 100Ω and 1KΩ @0°C, 385 curve,
 Pt Accuracy (Std): 0.12% @Ref, or ±0.55°F, (±0.3°C)
 Pt Accuracy (High): 0.06% @Ref, or ±0.277°F,
 (±0.15°C), [A]option
 Pt Stability: ±0.25°F, (±0.14°C)
 Pt Self Heating: 0.4 °C/mW @0°C
 Pt Probe Range: -40° to 221°F, (-40 to 105°C)
 Wire Colors: General color code (other colors possible)
 1KΩ, Class B Orange/Orange (no polarity)
 1KΩ, Class A Orange/White (no polarity)
 100Ω, Class B Red/Red (no polarity)
 100Ω, Class A Red/Red-w/black stripe (no polarity)

Sensitivity: Approximate @ 32°F (0°C)
 Thermistor Non-linear - (See www.bapihvac.com, click "Sensor Specs")
 RTD (Pt): 3.85Ω/°C for 1KΩ RTD
 0.385Ω/°C for 100Ω RTD
Lead Wire: 22awg stranded
Insulation: Etched Teflon, Plenum rated
Probe: Vented polycarbonate shield, 1/2" OD
Probe Length: 1.2" w/ 1/2" NPT threads
Wall Gasket: 1/4" Closed cell foam (impervious to mold)
Mounting: Extension tabs (ears), 3/16" holes

Enclosure Types:

Weatherproof: **-WP**, w/ two 1/2" FNPT entries, (Bell box)
 BAPI-Box: **-BB**, w/ four 1/2" NPSM & one 1/2" drill-out
 BAPI-Box 2: **-BB2**, w/ three 1/2" NPSM & three 1/2" drill-outs
 Weather Tight: **-EU**, w/ two 1/2" knock-outs

Enclosure Ratings:

Weatherproof: **-WP**, NEMA 3R, IP14
 BAPI-Box: **-BB**, NEMA 4, IP66
 BAPI-Box 2: **-BB2**, NEMA 4, IP66
 Weather Tight: **-EU**, NEMA 4, IP66

Enclosure Material:

Weatherproof: **-WP**, Cast Aluminum
 BAPI-Box: **-BB**, Polycarbonate, UL94V-0, UV rated
 BAPI-Box 2: **-BB2**, Polycarbonate, UL94V-0, UV rated
 Weather Tight: **-EU**, ABS Plastic, UL94V-0, UV rated

Ambient (Enclosure): 0 to 100% RH, Non-condensing

Weatherproof: **-WP**, -40°F to 212°F, (-40° to 100°C)
 BAPI-Box: **-BB**, -40°F to 185°F, (-40° to 85°C)
 BAPI-Box 2: **-BB2**, -40°F to 185°F, (-40° to 85°C)
 Weather Tight: **-EU**, -40°F to 185°F, (-40° to 85°C)

Agency:

RoHS
 PT= DIN43760, IEC Pub 751-1983,
 JIS C1604-1989